

A modern, high-performing downlight suitable for commercial and residential applications. Die cast aluminium body with a high efficiency reflector and clear polycarbonate lens. High quality LED technology ensures the luminaire's long life while maintaining colour quality.

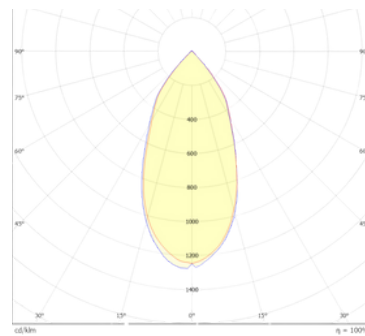
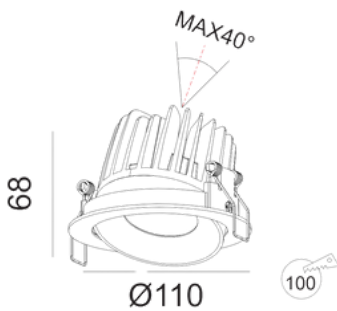

### MECHANICAL

Installation	Recessed
Housing Material	Aluminium
Lens Material	Clear Polycarbonate
Ingress Protection	IP20
Luminaire Diameter	110mm
Cut-Out Diameter	100mm
Luminaire Depth	75mm
Adjustable	Max. Tilt ±20°

### ELECTRICAL

Driver Included	Yes
Voltage Input	230V AC
Drive Current	350mA

### LIGHT SOURCE

LED Manufacturer	Cree
LED Series	CXA1512
Beam Angle	60°
Luminaire Lumens	1,338lm
Luminaire Efficacy	89.20lm/W
Luminaire Power	15W
Colour Rendition (CRI)	Ra 92
Colour Consistency	SDCM 3
Lifetime	L90 B10 60,000hrs



### LUMINAIRE OPTIONS

POWER	CODE	CCT	CODE	COLOUR	CODE	DIMMING	CODE
15W	15	2700K	W27	WHITE	W	TRAILING EDGE	T
18W	18	3000K	W30	BLACK	B	1-10V	A
		4000K	W40	CUSTOM	C	DALI	D
		BLUE	BL			CASAMBI	C

### CODE GENERATION

	LUMINAIRE	POWER	CCT	COLOUR	DIMMING
CODE	HR-1037	15	W30	W	T
REQUIREMENTS	HUNTER	15W	3000K	WHITE	TRAILING EDGE

**COMPLETE CODE = HR-1037-15-W30-W-T**